

ZANUSSI

BUILT-IN OVEN

ZOB 160

INSTRUCTION BOOKLET

Please read this instruction booklet before using the appliance

GB

Important Safety Information



You **MUST** read these warnings carefully before installing or using the hob. If you need assistance, contact our Customer Care Department on 08705 727727.

Installation

- This oven must be installed by qualified personnel to the relevant British Standards.
- This oven is heavy. Take care when moving it.
- Remove all packaging, both inside and outside the oven, before using the oven.
- Do not attempt to modify the oven in any way.

Child Safety

- This oven is designed to be operated by adults. Do not allow children to play near or with the oven.
- The oven gets hot when it is in use. Children should be kept away until it has cooled.
- This appliance is not intended for use by children or other persons whose physical, sensory or mental capabilities or lack of experience and knowledge prevents them from using the appliance safely without supervision or instruction by a responsible person to ensure that they can use the appliance safely.

During Use

- This oven is intended for domestic cooking only. It is not designed for commercial or industrial purposes.
- Appliances become very hot with use, and retain their heat for long periods after use. Care should be taken to avoid touching heating elements inside the oven.
- **Always stand back from the oven when opening the oven door during cooking or at the end of it to allow any build up of steam or heat to release.**
- Never line any part of the oven with aluminium foil.
- Do not allow heatproof cooking material, e.g. roasting bags, to come into contact with oven elements.
- Never place plastic or any other material which may melt in or on the oven.
- Do not place sealed cans or aerosols inside the oven. They may explode if they are heated.
- Do not hang towels, dishcloths or clothes from the oven or its handle.
- Do not use this oven if it is in contact with water and never operate it with wet hands.

- Take great care when heating fats and oils as they will ignite if they become too hot.
- Always use oven gloves to remove and replace food in the oven.
- Ensure that all control knobs are in the OFF position when not in use.
- Do not leave cookware containing foodstuffs, e.g. fat or oil in or on the oven in case it is inadvertently switched ON.
- When using other electrical appliances, ensure the cable does not come into contact with the hot surfaces of the oven.

Maintenance and Cleaning

- Only clean this oven in accordance with the instructions.
- The oven should be kept clean at all times. A build-up of fats or other foodstuffs could result in a fire, especially in the grill pan.
- Never use steam or high pressure steam cleaners to clean the appliance.
- Do not use harsh abrasive cleaners or sharp metal scraper to clean the oven door glass since they can scratch the surface, which may result in shattering of the glass.
- Always allow the oven to cool down and switch off the electrical supply before carrying out any cleaning or maintenance work.

Service

- This oven should only be repaired or serviced by an authorised Service Engineer and only genuine approved spare parts should be used.

Contents

For the User

Important Safety Information	2
Guide to Use the instructions	3
Description of the Appliance	4
Controls	5
Before the First Use	6
Hints and Tips	7
The Conventional Oven	9
Cooking Chart - Conventional Oven	9
Grilling	10
Cleaning the Oven	11
Something not working	12
Guarantee/Customer Service	15
European guarantee	16

For the Installer

Technical Data	13
Electrical Connection	13
Building In	14

Guide to Use the instructions

Environmental Information

- After installation, please dispose of the packaging with due regard to safety and the environment.
- When disposing of an old appliance, make it unusable, by cutting off the cable. Remove any door catches, to prevent small children being trapped inside.

- The symbol  on the product or on its packaging indicates that this product may not be treated as household waste. Instead it shall be handed over to the applicable collection point for the recycling of electrical and electronic equipment. By ensuring this product is disposed of correctly, you will help prevent potential negative consequences for the environment and human health, which could otherwise be caused by inappropriate waste handling of this product. For more detailed information about recycling of this product, please contact your local city office, your household waste disposal service or the shop where you purchased the product.

The following symbols will be found in the text to guide you throughout the Instructions:



Safety Instructions



Step by step instructions for an operation



Hints and Tips



Environmental information



This appliance complies with the following **E.E.C. Directives:**

- * **73/23 - 90/683**
(Low Voltage Directive);
- * **93/68** (General Directives);
- * **89/336** (Electromagnetical Compatibility Directive) .
and subsequent modifications

Keep this instruction book for future reference and ensure it is passed on to any new owner.

Description of the Appliance

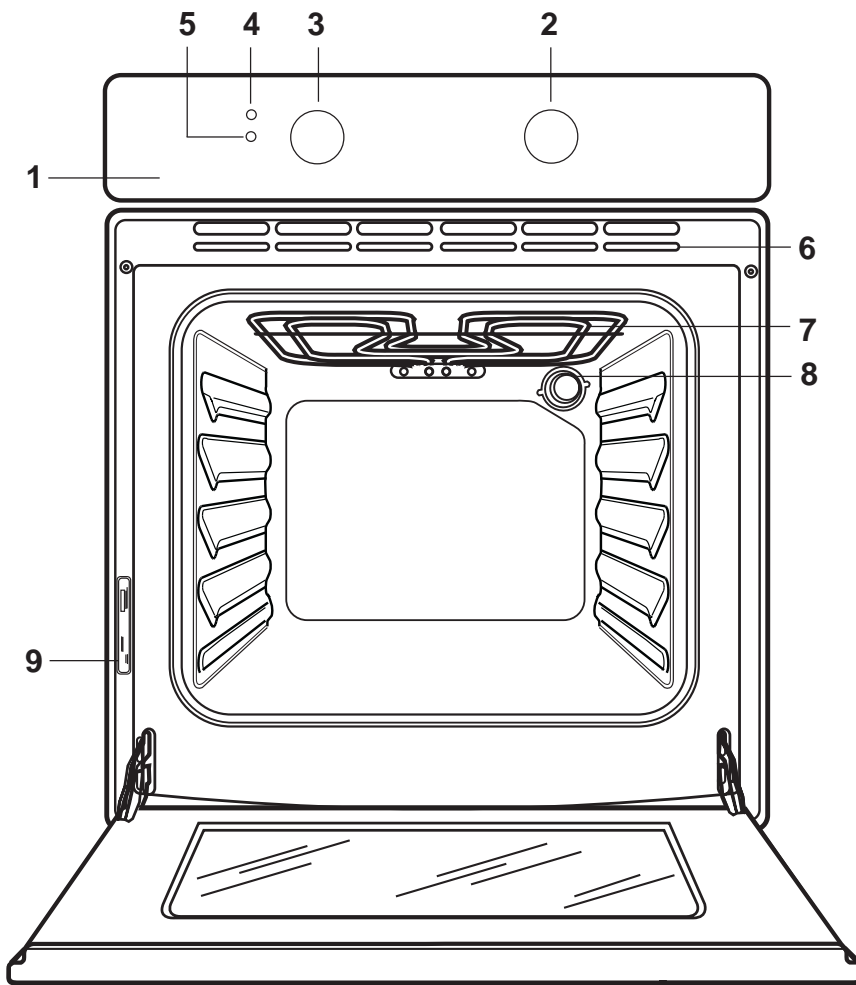



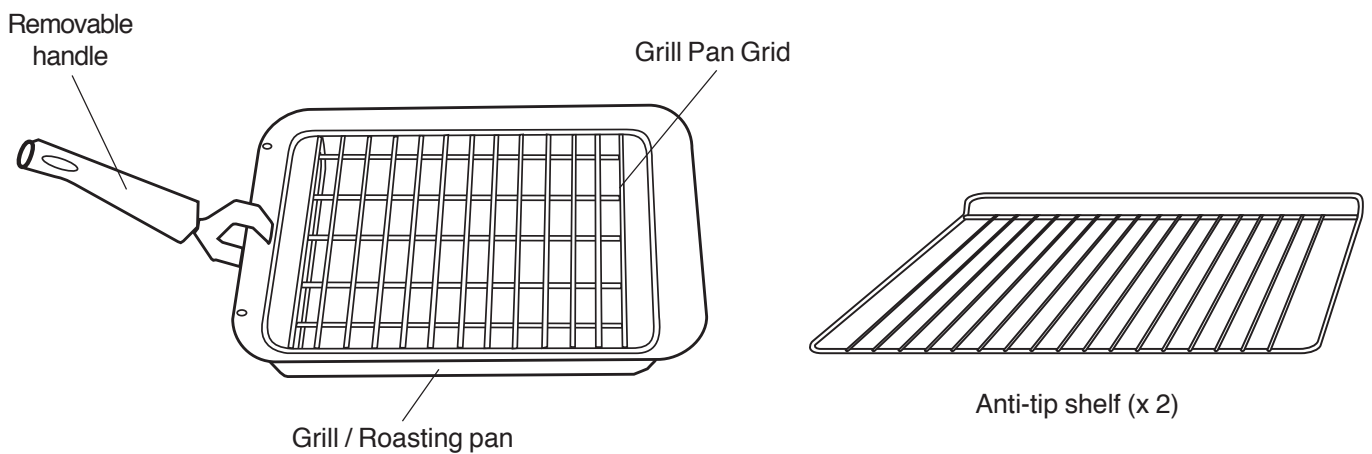

1. Control Panel
2. Oven Function Control Knob
3. Thermostat Control Knob
4. Mains On Indicator
5. Thermostat Control Indicator
6. Air Vents for Cooling Fan
7. Grill
8. Oven light
9. Rating plate

Oven accessories



Controls

Oven Function Control Knob

- 0** The oven is off
-  Conventional cooking - The heat comes from both the top and bottom element, ensuring even heating inside the oven
-  Bottom heating element - The heat comes from the bottom of the oven only
-  Top heating element - The heat comes from the top element only (outer section)
-  Inner grill element only - Can be used for grilling small quantities
-  Full Grill - The full grill element will be on

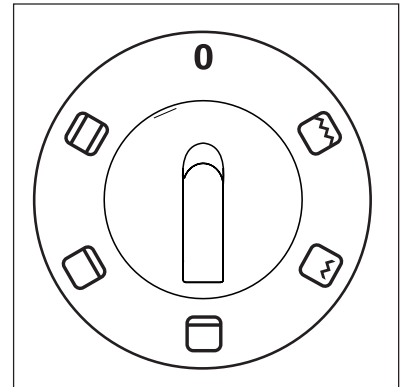

Mains on Indicator

The mains on light will come on when the oven function control knob is set.

Thermostat Control Knob

Turn the thermostat control knob clockwise to select temperatures between 50°C and MAX (230°C).

Thermostat Control Indicator (°C)

The thermostat control indicator will come on when the thermostat control knob is turned. The indicator will remain on until the correct temperature is reached. It will then cycle on and off to show the temperature is being maintained.

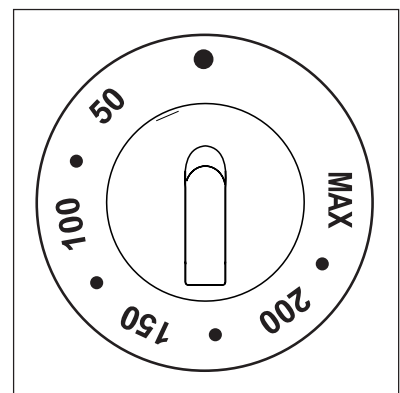

The Safety Thermostat

This oven is provided with a safety thermostat. In case of malfunctioning of the main thermostat, and consequent over-heating, the safety device will stop the power supply to the appliance. If this happens, call your local Service Force Centre. Under no circumstances should you attempt to repair the appliance yourself.

The cooling fan

The cooling fan operates during cooking. Air is expelled through vents between the oven door and the control panel, as shown in the diagram.

The cooling fan may run on after the oven is switched off to keep the controls cool. This is quite normal.

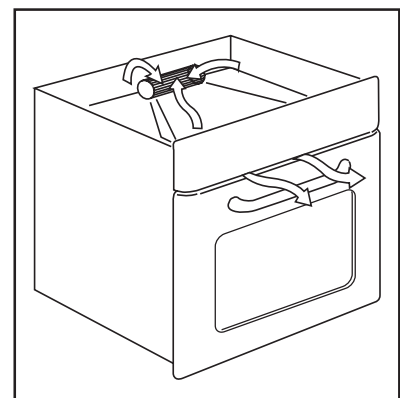



Before the First Use

i Remove **all packaging**, both inside and outside the oven, before using the appliance.

Before first use, the oven should be heated without food. During this time, an unpleasant odour may be emitted. This is quite normal.

Ensure the room is well ventilated.

- 1.** Switch the oven function control knob to conventional cooking .
- 2.** Set the thermostat control knob to MAX.
- 4.** Open a window for ventilation.
- 5.** Allow the oven to run empty for approximately 45 minutes.

This procedure should be repeated with the full grill function  for approximately 5-10 minutes.

Using the Oven

! **Always cook with the oven door closed.** Stand clear when opening the drop down oven door. **Do not** allow it to fall open - support the door using the door handle, until it is fully open.

i The oven has four shelf levels, and is supplied with two shelves. The shelf positions are counted from the bottom of the oven as shown in the diagram. It is important that these shelves are correctly positioned as shown in the diagram. Do not place cookware directly on the oven base.

! Be careful when you insert and remove the grid and the dripping pan from the oven in order not to damage the enamelled surfaces of the oven cavity.

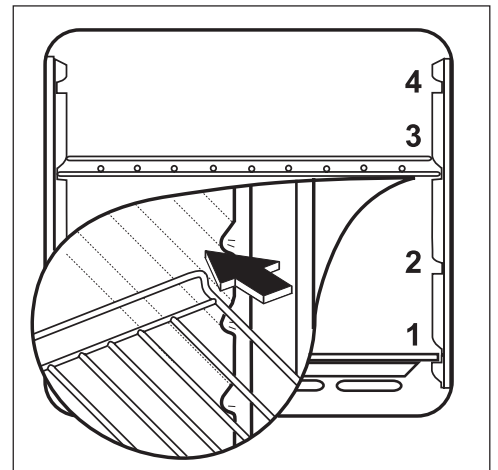

Hints and Tips

Condensation and steam

The oven is supplied with an exclusive system which produces a natural circulation of air and the constant recycling of steam.

This system makes it possible to cook in a steamy environment and keep the dishes soft inside and crusty outside. Moreover, the cooking time and energy consumption are reduced to a minimum. During cooking steam may be produced which can be released when opening the oven door. This is absolutely normal.



However, always stand back from the oven when opening the oven door during cooking or at the end of it to allow any build up of steam or heat to release.



When food is heated, it produces steam in the same way as a boiling kettle does. When steam comes in contact of the oven door glass, it will condense and produce water droplets. To reduce condensation, ensure the oven is well heated before placing food in the oven cavity. A short oven pre-heating (about 10 minutes) will then be necessary before any cooking. We recommend you to wipe away condensation after each use of the appliance.

Cookware

- Use any oven proof cookware which will withstand temperatures of 230°C.
- Baking trays, oven dishes, etc. should not be placed on the oven base.
- Do not use baking trays larger than 30 cm x 35 cm (12 in x 14 in) as they will restrict the circulation of heat and may affect performance.

The effects of dishes on cooking results

Dishes and tins vary in their thickness, conductivity, colour, etc. which affects the way they transmit heat to the food inside them.

A Aluminium, earthenware, oven glassware and bright shiny utensils reduce cooking and base browning.

B Enamelled cast iron, anodized aluminium, aluminium with non-stick interior and coloured exterior and dark, heavy utensils increase cooking and base browning.



Attention! - Do not place objects on the oven base and do not cover any part of the oven with aluminium foil while cooking, as this could cause a heat build-up which would affect the baking results and damage the oven enamel. Always place pans, heat-resisting pans and aluminium trays on the grid which has been inserted in the oven shelves.



Attention! - Be careful when you insert and extract the grid and the drip tray from the oven in order not to damage the enamelled surfaces of the oven cavity.

The Conventional Oven

When using this setting, heat comes from both the top and bottom elements. This allows you to cook on a single level and is particularly suitable for dishes which require extra base browning such as quiches and flans. Gratins, lasagnes and hotpots which require extra top browning also cook well in the conventional oven.

How to use the conventional oven

1. Turn the oven function control knob to the required cooking function ().
2. Turn the thermostat control knob to the required temperature.

Top oven element only

This function is suitable for finishing cooked dishes, e.g. lasagne, shepherds pie, cauliflower cheese etc.

Bottom oven element only

This function is particularly useful when blind-baking pastry. It may also be used to finish off quiches or flans to ensure the base pastry is cooked through.

THINGS TO NOTE

- The thermostat control light will remain on until the correct temperature is reached. It will then cycle on and off to show the temperature is being maintained.

Hints and Tips

- The middle shelf position allows for the best heat distribution. To increase base browning simply lower the shelf position. To increase top browning, raise the shelf position.
- The material and finish of the baking trays and dishes used will affect base browning. Enamelware, dark, heavy or non-stick utensils increase base browning, while oven glassware, shiny aluminium or polished steel trays reflect the heat away and give less base browning.
- Always place dishes centrally on the shelf to ensure even browning.
- Stand dishes on suitably sized baking trays to prevent spillage onto the base of the oven and make cleaning easier.
- **Do not** place dishes, tins or baking trays directly on the oven base as it becomes very hot and damage will occur.

Cooking Chart - Conventional Oven

These charts are intended as a guide only. It may be necessary to increase or decrease the temperature to suit your individual requirements. Only experience will enable you to determine the correct setting for your personal requirements.

i Cooking times in the tables do not include pre-heating. We recommend to pre-heat the oven for about 10 minutes before cooking.

Weight (gr.)	Type of dish	Shelf position 	Temperature °C	Cooking time in minutes	Notes
	CAKES				
	Whisked recipes	2	170	45 ~ 60	In cake mould
	Shortbread dough	2	170	20 ~ 30	In cake mould
	Butter-milk cheese cake	1	160	60 ~ 80	In cake mould
	Apple cake	1	180	40 ~ 60	In cake mould
	Strudel	2	175	60 ~ 80	
	Jam-tart	2	175	30 ~ 40	
	Fruit cake	1	175	45 ~ 60	In bread tin
	Sponge cake	1	175	30 ~ 40	In cake mould
	Christmas cake	1	170	40 ~ 60	In cake mould
	Plum cake	1	170	50 ~ 60	In bread pan
	Small cakes	2	175	25 ~ 35	In baking tray
	Biscuits	2	160	20 ~ 30	In baking tray
	Meringues	2	100	90 ~ 120	In baking tray
	Buns	2	190	12 ~ 20	In baking tray
	Pastry: Choux	2	200	15 ~ 25	In baking tray
	BREAD AND PIZZA				
1000	White bread	1	190	40 ~ 60	1-2 pieces
500	Rye bread	1	190	30 ~ 45	In bread tin
500	Bread rolls	2	200	20 ~ 35	6-8 rolls
250	Pizza	1	210	15 ~ 30	on baking tray
	FLANS				
	Pasta flan	2	200	40 ~ 50	in mould
	Vegetable flan	2	200	45 ~ 60	in mould
	Quiches	1	200	35 ~ 45	in mould
	Lasagne	2	180	45 ~ 60	in mould
	Cannelloni	2	200	40 ~ 55	in mould
	MEAT				
1000	Beef	2	190	50 ~ 70	On grid
1200	Pork	2	180	100 ~ 130	On grid
1000	Veal	2	190	90 ~ 120	On grid
1500	English roast beef				
1500	underdone	2	210	50 ~ 60	On grid
1500	done	2	210	60 ~ 70	On grid
1500	well done	2	210	70 ~ 80	On grid
2000	Shoulder of pork	2	180	120 ~ 150	with rind
1200	Shin of pork	2	180	100 ~ 120	2 pieces
1200	Lamb	2	190	110 ~ 130	Leg
1000	Chicken	2	190	60 ~ 80	Whole
4000	Turkey	2	180	210 ~ 240	Whole
1500	Duck	2	175	120 ~ 150	Whole
3000	Goose	2	175	150 ~ 200	Whole
1200	Rabbit	2	190	60 ~ 80	Cut in pieces
1500	Hare	2	190	150 ~ 200	Cut in pieces
800	Pheasant	2	190	90 ~ 120	Whole
	Meat loaf	2	180	40 ~ 60	In bread pan
	FISH				
1200	Trout/Sea bream	2	190	30 ~ 40	3-4 fishes
1500	Tuna fish/Salmon	2	190	25 ~ 35	4-6 fillets

NOTE: Shelf positions are counted from bottom of the oven.

Grilling



Grilling must be carried out with the oven door closed.

The grill pan handles must be removed from the pan during grilling. Always use oven gloves to remove and replace the grill pan handles. Ensure that you **support** the grill pan when removing it from the oven.

How to Use the Full Grill

1. Turn the oven control function knob on .
2. Turn the thermostat control knob on the required temperature.
3. Adjust the grid and grill pan runner position to allow for different thicknesses of food. Position the food close to the element for faster cooking and further away for more gentle cooking.

Preheat the grill on a full setting for a few minutes before sealing steaks or toasting. Adjust the heat setting and the shelf as necessary, during cooking.

During cooking, the cooling fan and the thermostat control light will operate in the same way as described for the fan oven function.

How to Use the Inner Grill

Element

The inner grill provides quick direct heat to the central area of the grill pan. By using the inner grill element for cooking small quantities, it can help to save energy.

1. Turn the oven control function knob on .
2. Turn the thermostat control knob on the required temperature.
3. Adjust the grid and grill pan runner position to allow for different thicknesses of food and follow the instructions for grilling.

Hints and Tips

- Most foods should be placed on the grid in the grill pan to allow maximum circulation of air and to lift the food out of the fats and juices. Food such as fish, liver and kidneys may be placed directly on the grill pan, if preferred.
- Food should be thoroughly dried before grilling to minimise splashing. Brush lean meats and fish lightly with a little oil or melted butter to keep them moist during cooking.
- Accompaniments such as tomatoes and mushrooms may be placed underneath the grid when grilling meats
- When toasting bread, we suggest that the top runner position is used.
- The food should be turned over during cooking, as required.

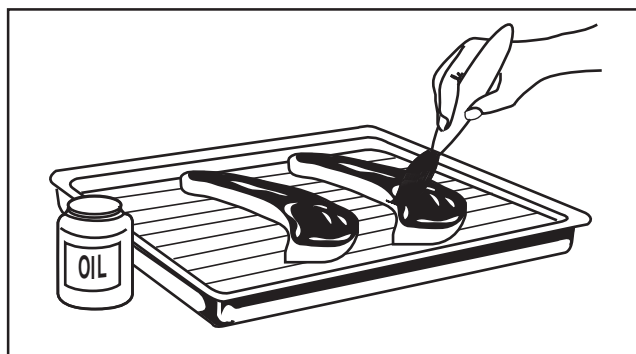

The grill element is controlled by the thermostat. During cooking, the grill cycles on and off to prevent overheating.



Cooking chart - Grilling -





Cooking times in the tables do not include pre-heating. We recommend to pre-heat the oven for about 10 minutes before cooking.

TYPE OF DISH	Quantity		Grilling		Cooking time (minutes) 	
	Pieces	Weight	Level 	temp. °C	Upper side	Lower side
Fillet steaks	4	800	3	max	12 ~ 15	12 ~ 14
Beef-steaks	4	600	3	max	10 ~ 12	6 ~ 8
Sausages	8	—	3	max	12 ~ 15	10 ~ 12
Pork chops	4	600	3	max	12 ~ 16	12 ~ 14
Chicken (cut in two)	2	1000	3	max	30 ~ 35	25 ~ 30
Kebabs	4	—	3	max	10 ~ 15	10 ~ 12
Chicken (breast)	4	400	3	max	12 ~ 15	12 ~ 14
Hamburger	6	600	3	max	10 ~ 15	8 ~ 10
Fish (fillets)	4	400	3	max	12 ~ 14	10 ~ 12
Sandwiches	4-6	—	3	max	5 ~ 7	—
Toast	4-6	—	3	max	2-4	2 ~ 3

The chart is intended as a guide only and should be adjusted according to taste. Cooking time depends on the thickness of the meat and not on its weight.

Cleaning the Oven

 **Before cleaning always allow the cooling fan to cool the cooker down before switching off at the electricity supply.**

 The oven should be kept clean at all times. A build-up of fats or other foodstuffs could result in a fire, especially in the grill pan.

Cleaning materials

Before using any cleaning materials on your oven, check that they are suitable and that their use is recommended by the manufacturer.

Cleaners that contain bleach should **NOT** be used as they may dull the surface finishes. Harsh abrasives should also be avoided.

External cleaning

Regularly wipe over the control panel, oven door and door seal using a soft cloth well wrung out in warm water to which a little liquid detergent has been added.

To prevent damaging or weakening the door glass panels avoid the use of the following:

-  • Household detergent and bleaches
- Impregnated pads unsuitable for non-stick saucepans
- Brillo/Ajax pads or steel wool pads
- Chemical oven pads or aerosols
- Rust removers
- Bath/Sink stain removers

Clean the outer and inner door glass using warm soapy water. Should the inner door glass become heavily soiled it is recommended that a cleaning product such as Hob Brite is used.

 **DO NOT clean the oven door while the glass panels are warm. If this precaution is not observed the glass panel may shatter.**

If the door glass panel becomes chipped or has deep scratches, the glass will be weakened and must be replaced to prevent the possibility of the panel shattering. Contact your local Service Force Centre who will be pleased to advise further.

Stainless steel or aluminium appliances:

We recommend that the oven door is only cleaned using a wet sponge and dried after cleaning with a soft cloth. Never use steel wool, acids or abrasive products as they can damage the oven surface.

Clean the oven control panel following the same precautions.

Oven Cavity

The enamelled base of the oven cavity is best cleaned whilst the oven is still warm.

Wipe the oven over with a soft cloth soaked in warm soapy water after each use. From time to time it will be necessary to do a more thorough cleaning, using a proprietary oven cleaner.

Replacing The Oven Light

Disconnect the appliance

If the oven bulb needs replacing, it must comply with the following specifications:

- Electric power: 15 W/25 W,
- Electric rate: 230 V (50 Hz),
- Resistant to temperatures of 300°C,
- Connection type: E14.

These bulbs are available from your local Service Force Centre.

To replace the faulty bulb:

1. Ensure the oven is isolated from the electrical supply.
2. Push in and turn the glass cover anticlockwise.
3. Remove the faulty bulb and replace with the new one.
4. Refit the glass cover and restore the electrical supply.

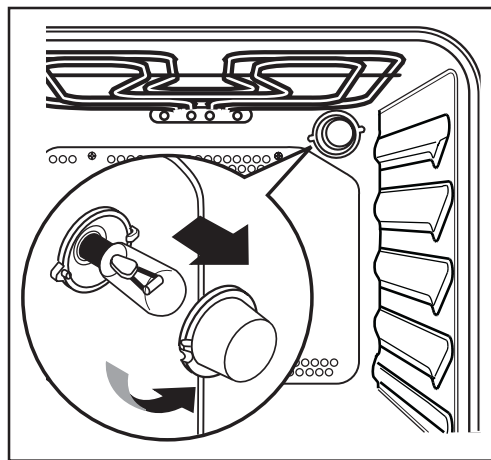

Something not working

If the appliance is not working correctly, please carry out the following checks, before contacting your local Service Force Centre.

IMPORTANT: If you call out an engineer to a fault listed below, or to repair a fault caused by incorrect use or installation, a charge will be made even if the appliance is under guarantee.

SYMPTOM	SOLUTION
<ul style="list-style-type: none"> ■ The oven does not come on 	<ul style="list-style-type: none"> ◆ Check that both a cooking function and temperature have been selected. ◆ Check the appliance is wired in properly, and the socket switch or the switch from the mains supply to the oven are ON.
<ul style="list-style-type: none"> ■ The oven temperature light does not come on 	<ul style="list-style-type: none"> ◆ Select a temperature with the thermostat control knob ◆ Select a function with the oven function control knob.
<ul style="list-style-type: none"> ■ The oven light does not come on 	<ul style="list-style-type: none"> ◆ Select a function with the oven function control knob ◆ Check the light bulb, and replace it if necessary (see "Cleaning the Oven")
<ul style="list-style-type: none"> ■ It takes too much time to finish the dishes, or they are cooked too fast. 	<ul style="list-style-type: none"> ◆ The temperature may need adjusting ◆ Refer to the contents of this booklet, especially to the chapter "Using the Oven".
<ul style="list-style-type: none"> ■ Steam and condensation settle on the food and the oven cavity. 	<ul style="list-style-type: none"> ◆ Leave dishes inside the oven no longer than 15-20 minutes after the cooking is completed.

If after all these checks, the oven still does not work, contact your local Service Force Centre quoting your model and serial number, which can be found on the rating plate. Please note that it will be necessary to provide proof of purchase for any in-guarantee service calls.

In-guarantee customers should ensure that the above checks have been made as the engineer will make a charge if the fault is not a mechanical or electrical breakdown.

Technical Data

 *The oven must be installed according to the instructions supplied.*

Heating element ratings

Top element	800 W
Bottom element	1,000 W
Oven elements (total)	1,800 W
Inner Grill element	1,650 W
Full Grill element	2,450 W
Oven Light	25 W
Total Rating	2,500 W
Supply voltage (50 Hz)	230 V

 *This oven must be installed by **qualified personnel** to the relevant British Standards.*

Dimensions of recess

Height	undertop	593 mm
	in column	580 mm
Width		560 mm
Depth		550 mm

Dimensions of the oven cavity

Height	335 mm
Width	405 mm
Depth	410 mm
Oven capacity	56 litres

Electrical Connection

The oven is designed to be connected to 230 V (50Hz) electricity supply.

The oven has an easily accessible terminal block which is marked as follows:

Letter L	-	Live terminal
Letter N	-	Neutral terminal
 or E	-	Earth terminal

THIS OVEN MUST BE EARTHED

The cable used to connect the oven to the electrical supply must comply to the specifications given below.

For Uk use only

Connection via	Min. size Cable/flex	Cable / flex type	Fuse
• Cooker Control Circuit	2.5 mm ²	PVC/PVC twin and earth	20 A

For Europe use only

Min. size Cable/flex	Cable / flex type	Fuse
2.5 mm ²	H07 RN-F, H05 RN-F, H05 RR-F, H05 VV-F, H05 V2V2-F (T90), H05 BB-F	15 A

It is necessary that you install a double pole switch between the oven and the electricity supply (mains), with a minimum gap of 3mm between the switch contacts and of a type suitable for the required load in compliance with the current rules.

The switch must not break the yellow and green earth cable at any point.

The yellow and green earth cable should be 2-3 cm. longer than the other cables.

Πορτ;ντ

After installation and connecting, the cable must be placed so that it cannot at any point reach a temperature of more than 50°C above the ambient temperature.

Before the oven is connected, check that the main fuse and the domestic installation can support the load; and that the power supply is properly earthed.

The manufacturer disclaims any responsibility should these safety measures not be carried out.

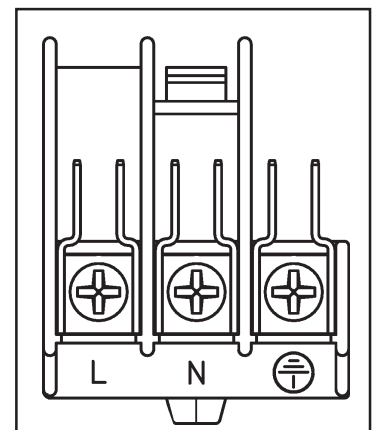

Building In

Please ensure that when the oven is installed it is easily accessible for the engineer in the event of a breakdown.

BUILDING IN

The surround or cabinet into which the oven will be built must comply with these specifications:

- the dimensions must be as shown in the relevant diagrams;
- the materials must withstand a temperature increase of at least 60°C the above temperature;
- proper arrangements must be made for a continuous supply of air to the oven to prevent the oven overheating.

Dimensions of the oven and recess required are given in the relevant diagrams.

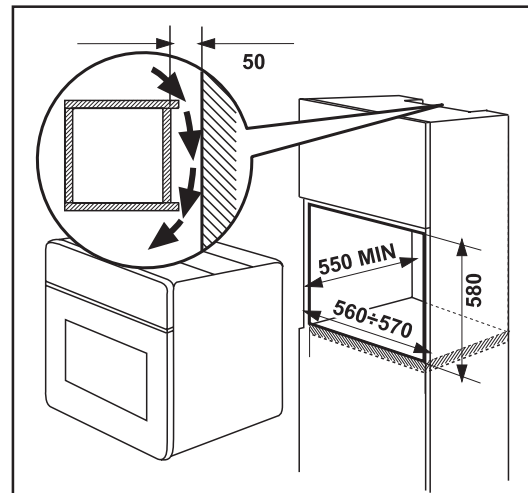
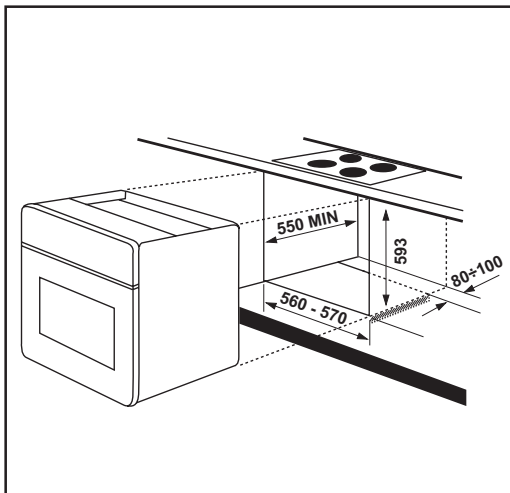
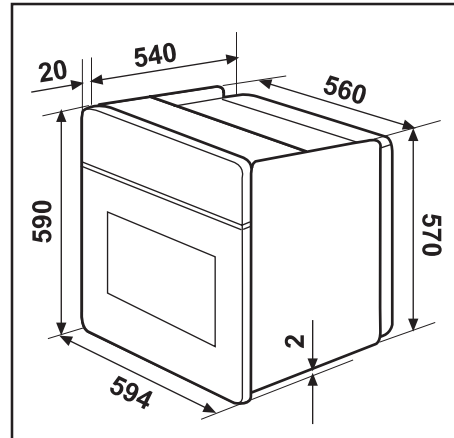

Securing The Oven To The Cabinet

1. Fit the oven into the cabinet recess,
2. Open the oven door
3. Secure the oven to the kitchen cabinet with four wood screws, which fit the holes provided in the oven frame.

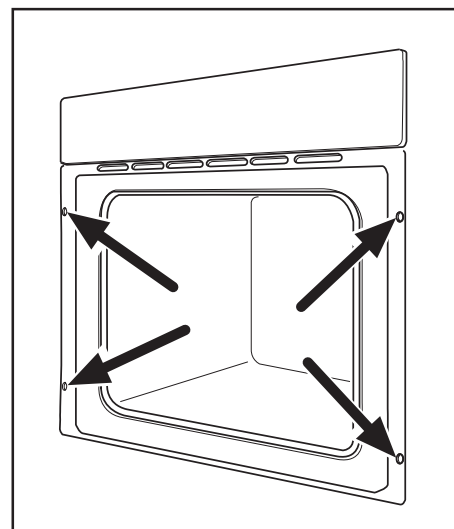

Guarantee/ Customer Service

Standard guarantee conditions

We, Zanussi-Electrolux, undertake that if within 12 months of the date of the purchase this Zanussi-Electrolux appliance or any part thereof is proved to be defective by reason only of faulty workmanship or materials, we will, at our option repair or replace the same FREE OF CHARGE for labour, materials or carriage on condition that:

- The appliance has been correctly installed and used only on the electricity supply stated on the rating plate.
- The appliance has been used for normal domestic purposes only, and in accordance with the manufacturer's instructions.
- The appliance has not been serviced, maintained, repaired, taken apart or tampered with by any person not authorised by us.
- Electrolux Service Force Centre must undertake all service work under this guarantee.
- Any appliance or defective part replaced shall become the Company's property.
- This guarantee is in addition to your statutory and other legal rights.

Exclusions

- Damage or calls resulting from transportation, improper use or neglect, the replacement of any light bulbs or removable parts of glass or plastic.
- Costs incurred for calls to put right an appliance which is improperly installed or calls to appliances outside the United Kingdom.
- Appliances found to be in use within a commercial environment, plus those which are subject to rental agreements.
- Products of Electrolux manufacturer that are not marketed by Electrolux.

Service and Spare Parts

In the event of your appliance requiring service, or if you wish to purchase spare parts, please contact your local Service Force Centre by telephoning

0870 5 929 929

Your telephone call will be automatically routed to the Service Force Centre covering your postcode area.

For the address of your local Service Force Centre and further information about Service Force, please visit the website at

www.serviceforce.co.uk

Before calling out an engineer, please ensure you have read the details under the heading "Something not working"

When you contact the Service Force Centre you will need to give the following details:

1. Your name, address and postcode.
2. Your telephone number.
3. Clear concise details of the fault.
4. The model and Serial number of the appliance (found on the rating plate).
5. The purchase date.

Please note a valid purchase receipt or guarantee documentation is required for in guarantee service calls.

Customer Care

For general enquiries concerning your Electrolux appliance, or for further information on Electrolux products please contact our Customer Care Department by letter or telephone at the address below or visit our website at www.electrolux.co.uk

Customer Care Department
Electrolux Major Appliances
Addington Way
Luton
Bedfordshire, LU4 9QQ
Tel: 08705 727 727 (*)

(*) Calls may be recorded for training purposes

European guarantee

This appliance is guaranteed by Electrolux in each of the countries listed at the back of this user manual, for the period specified in the appliance guarantee or otherwise by law. If you move from one of these countries to another of the countries listed below the appliance guarantee will move with you subject to the following qualifications:

- The appliance guarantee starts from the date you first purchased the appliance which will be evidenced by production of a valid purchase document issued by the seller of the appliance.
- The appliance guarantee is for the same period and to the same extent for labour and parts as exists in your new country of residence for this particular model or range of appliances.
- The appliance guarantee is personal to the original purchaser of the appliance and cannot be transferred to another user.
- The appliance is installed and used in accordance with instructions issued by Electrolux and is only used within the home, i.e. is not used for commercial purposes.
- The appliance is installed in accordance with all relevant regulations in force within your new country of residence.

The provisions of this European Guarantee do not affect any of the rights granted to you by law.

		
Albania	+35 5 4 261 450	Rr. Pjeter Bogdani Nr. 7 Tirane
Belgique/België/Belgien	+32 2 363 04 44	Bergensesteenweg 719, 1502 Lembeek
Česká republika	+420 2 61 12 61 12	Budějovická 3, Praha 4, 140 21
Danmark	+45 70 11 74 00	Sjællandsgade 2, 7000 Fredericia
Deutschland	+49 180 32 26 622	Muggenhofer Str. 135, 90429 Nürnberg
Eesti	+37 2 66 50 030	Mustamäe tee 24, 10621 Tallinn
España	+34 902 11 63 88	Carretera M-300, Km. 29,900 Alcalá de Henares Madrid
France	www.electrolux.fr	
Great Britain	+44 8705 929 929	Addington Way, Luton, Bedfordshire LU4 9QQ
Hellas	+30 23 10 56 19 70	4, Limnou Str., 54627 Thessaloniki
Hrvatska	+385 1 63 23 338	Slavonska avenija 3, 10000 Zagreb
Ireland	+353 1 40 90 753	Long Mile Road Dublin 12
Italia	+39 (0) 434 558500	C.so Lino Zanussi, 26 - 33080 Porcia (PN)
Latvija	+37 17 84 59 34	Kr. Barona iela 130/2, LV-1012, Riga
Lituanija	+370 5 27 80 609	Verkių 29, 09108 Vilnius, Lithuania
Luxembourg	+35 2 42 43 13 01	Rue de Bitbourg, 7, L-1273 Hamm
Magyarország	+36 1 252 1773	H-1142 Budapest XIV, Erzsébet királyné útja 87
Nederland	+31 17 24 68 300	Vennootsweg 1, 2404 CG - Alphen aan den Rijn
Norge	+47 81 5 30 222	Risløkkvn. 2 , 0508 Oslo
Österreich	+43 18 66 400	Herziggasse 9, 1230 Wien
Polska	+48 22 43 47 300	ul. Kolejowa 5/7, Warsaw
Portugal	+35 12 14 40 39 39	Quinta da Fonte - Edificio Gonçalves Zarco - Q 35 -2774-518 Paço de Arcos
Romania	+40 21 451 20 30	B-dul Timisoara 90, S6, Bucharest
Schweiz - Suisse - Svizzera	+41 62 88 99 111	Industriestrasse 10, CH-5506 Mägenwil
Slovenija	+38 61 24 25 731	Electrolux Ljubljana d.o.o., Gerbičeva 98, 1000 Ljubljana
Slovensko	+421 2 43 33 43 22	Electrolux Slovakia s.r.o., Electrolux Domáce spotrebiče SK, Seberínho 1, 821 03 Bratislava
Suomi	www.electrolux.fi	
Sverige	+46 (0)771 76 76 76	Electrolux Service, S:t Göransgatan 143, S-105 45 Stockholm
Türkiye	+90 21 22 93 10 25	Tarlabası caddesi no : 35 Taksim İstanbul
Россия	+7 095 937 7837	129090 Москва, Олимпийский проспект, 16, БЦ "Олимпик"

-	ES	DA	DE	EL	EN	FR	IT	NL	PT	SV	FI	ZANUSSI
1	Fabricante	Mærke	Hersteller	Προμηθευτής	Manufacturer	Fabricant	Costruttore	Fabrikant	Fabricante	Leverantör	Tavarantoimittaja	ZANUSSI
2	Modelo	Model	Modell	Μοντέλο	Model	Modèle	Modello	Model	Modelo	Modell	Malli	ZOB 160
3	Clase de eficiencia energética	Relativt energiforbrug	Energieeffizienzklasse	Τάξη ενεργειακής απόδοσης	Energy efficiency class	Classement selon son efficacité énergétique	Classe di efficienza energetica	Energie-efficientieklasse	Classe de eficiência energética	Energieeffektivitetsklass	Energiatohokkuusluokka	
4	- Calentamiento convencional	- Traditionel opvarmning	- Konventionelle Beheizung	- Συμβατική	- Conventional	- Classique	- Convezione naturale	- Convectioneel	- Convencional	- Konventionell värmning	- Ylä-alalämpö	
5	- Convección forzada	- Varmiluft	- Um/Heißluft	- Με κυκλοφορία θερμού αέρα	- Forced air convection	- Convection forcée	- Convezione forzata	- Geforceerde luchtconvectie	- Convecção forçada de ar	- Värmning med varmluft	- Kiertoilma	
6	Consumo de energía Función de calentamiento:	Energiforbrug Opvarmningsfunktion:	Energieverbrauch Beheizung:	Κατανάλωση ενέργειας Αιτιουργία θέρμανσης	Energy consumption Heating function:	Consommation d'énergie Fonction chauffage:	Consumo di energia Funzione di riscaldamento:	Energieverbruik Verhittingsfunctie:	Consumo de energia Função de aquecimento:	Energiförbrukning Värmningsfunktion:	Energiankulutus Kuumnennusta pa:	0,79 kWh
7	- Calentamiento convencional	- Traditionel opvarmning	- Konventionelle Beheizung	- Συμβατική	- Conventional	- Classique	- Convezione naturale	- Convectioneel	- Convencional	- Konventionell värmning	- Ylä-alalämpö	
8	- Vapor	- Damp	- Dampf	- Ατμός	- Steam	- Vapeur	- Vapore	- Stoom	- Vapor	- Ånga	- Höyry	
9	Volumen neto (litros)	Nettovolumen (liter)	Nettovolumen (Liter)	Ωφέλιμος όγκος (λίτρα)	Usable volume (litres)	Volume utile (litres)	Volume utile (litri)	Netto volume (liter)	Volume útil Litros	Användbar volym (liter)	Käyttötilavuus (litraa)	56,0
	Tipo: - Pequeño - Medio - Grande	Type: - Lille - Mellemstort - Stort	Typ: - Klein - Mittel - Groß	Τύπος: - Μικρός - Μεσαίος - Μεγάλος	Size: - Small - Medium - Large	Type: - Faible volume - Volume moyen - Grand volume	Tipo: - Piccolo - Medio - Grande	Type: - Klein - Middelgroot - Groot	Tipo: - pequeno - médio - grande	Storlek: - Liten - Medelstor - Stor	Koko: - Pieni - Keskipikokoinen - Suuri	
	Tiempo de cocción con carga normal:	Tilberedningstid ved standardbelastning:	Kochzeit bei Standardbelastung:	Χρόνος για ψησιμο τυποποιημένου φορτίου:	Time to cook standard load:	Temps de cuisson en charge normale:	Tempo necessario per cottura carico normale:	Bereidings-tijd bij standaardbelasting:	Tempo de cozedura da carga-padrão:	Tillagningstid för en standardlast:	Paistaika vakiokuumalla:	
10	- Calentamiento convencional	- Traditionel opvarmning	- Konventionelle Beheizung	- Συμβατική	- Conventional	- Classique	- Convezione naturale	- Convectioneel	- Convencional	- Konventionell värmning	- Ylä-alalämpö	43 min.
11	- Convección forzada	- Varmiluft	- Um/Heißluft	- Με κυκλοφορία θερμού αέρα	- Forced air convection	- Convection forcée	- Convezione forzata	- Geforceerde luchtconvectie	- Convecção forçada de ar	- Värmning med varmluft	- Kiertoilma	
12	Superficie de la placa de cocción de mayor tamaño	Arealet af den største bageplade	Größe des größten Backblechs	Η μεγαλύτερη επιφάνεια ψησίματος εκπορεύσιμη	The area of the largest baking sheet	Aire de la surface de la plus grande plaque pour pâtisserie	Superficie del piano di cottura più grande	Oppervlakte van de grootste bakplaat	Área da superfície da maior placa de pastelaria	Ytan för den största bakplåten	Suurimman leivinpellin ala	1130 cm ²
13	Ruido [dB (A) re 1 pW]	Lydeffektniveau dB (A) (Støj)	Geräusch [dB (A) re 1 pW]	Έμφυτος [dB (A) ανά 1 pW]	Noise [dB (A) re 1 pW]	Bruit [dB (A) re 1 pW]	Rumore [dB (A) re 1 pW]	Geluidsniveau dB (A) re 1 pW	Nível de ruído dB (A) re 1 pW	Bullemlivá dB (A)	Ääni [dB (A) re 1 pW]	
<p>● Más eficiente Lavi forbrug Niedriger Verbrauch Πιο αποδοτικό More efficient Économe</p> <p>Bassi consumi Efficient Mais efficace Låg förbrukning Vähän kuluttava</p> <p>A B C D E F G</p>							<p>Menos eficiente Højt forbrug Hoher Verbrauch Λιγότερο αποδοτικό Less efficient Peu économe</p> <p>Alti consumi Inefficient Menos eficiente Hög förbrukning Paljon kuluttava</p>		<p>●● 12 l ≤ Volumen neto/Nettovolumen/Ωφέλιμος όγκος/Usable volume/Volume utile/ Netto volume/Volume útil/Användbar volym/Käyttötilavuus < 35 l</p> <p>●●● 35 l ≤ Volumen neto/Nettovolumen/Ωφέλιμος όγκος/Usable volume/Volume utile/ Netto volume/Volume útil/Användbar volym/Käyttötilavuus < 65 l</p> <p>●●●● 65 l ≤ Volumen neto/Nettovolumen/Ωφέλιμος όγκος/Usable volume/Volume utile/ Netto volume/Volume útil/Användbar volym/Käyttötilavuus</p>		2002/40/EC	

www.electrolux.com
www.zanussi-electrolux.co.uk